

## **Design and Development of Processing Apparatus for Young Coconuts**

**Muhamad Hellmy Hussin**

*Fabrication & Joining Section, Universiti Kuala Lumpur Malaysia France Institute, Section 14, Jalan Teras Jernang, 43650 Bandar Baru Bangi, Selangor, Malaysia*

### **ABSTRACT**

As we know, drinking young coconut water and eating the tender meat give many benefit to the body for its nutritious value rather than its taste; but do we realize that it requires a dangerous tasks in processing it. The process of trimming requires skills which only can be obtained by those who run the work daily. Thus, a portable apparatus which has the capabilities of reducing the hazardous tasks and fasten the time consumed for processing the young coconut fruit has been proposed and developed. The development of the product begins with collecting and analyzing the data of 30 young coconut fruits. Then, it is followed by designing the whole product at main and component level. The conceptual design is done initially using freehand sketching technique. Next, the 3D solid modeling relies totally on the CATIA V5R19 software. Finally, a complete details drawing is produced using CAD software. In this work, the design focuses on the blade slicing and punch bit head to reduce the hazardous tasks during processing of the young coconut. The blade is designed to allow the slicing movement to be maneuvered during the husk removal process. Meanwhile, the puncher has replaced the usage of chopper in creating an opening at the top of the endocarp. Thus, the device developed will reduce the hazardous task by eliminating the chopping process and replacing it with the slicing process. Therefore, the tendency to get caught in accidental injury during the chopping process can be significantly reduced.

*Keywords:* CATIA, computer aided design, conceptual design, innovation, product design

### **INTRODUCTION**

Coconut fruit is among the 20 important crops in the world (Vidhan Singh & Udhayakumar, 2013). The coconut provides a nutritious source of juice, milk, and oil that has fed and nourished populations around

#### **ARTICLE INFO**

*Article history:*

Received:

Accepted:

Published: October 2018

*E-mail addresses:*

hellmy@unikl.edu.my

the world for generations (Lihua, 2015). On many islands coconut is a staple in diet and provides the majority of the food eaten (Mani & Jothilingam, 2014). Nearly, one third of the world's population depends on coconut to some degree for their food and their economy. The coconut is made of several layers (Adzimah & Turkson, 2015; Ketan, Vinod, & Sakhale, 2014). The outer layer where it is called the husk (mesocarp) is fibrous and the second layer is an inner "stone" (endocarp) and the third layer is the tender white meat, sort of jelly. The inner part is the cavity which filler with "coconut water" (Venkataramanan, Abhinav Ram, & Rahul, 2014). A very young coconut has very little meat (flesh), and the meat is very tender, almost a gel (Yahya & Zainal, 2014). For thousands of years, coconut products have held a respected and valuable place in local folk medicine (Syafriani, Apriantono, & Sigit, 2014). Meanwhile, modern medical science confirming the use of coconut in treating many conditions such as colds, constipation, cough, fever and flu (Yuniwarti, Asmara, Artama, & Tabbu, 2015).

As well known, drinking young coconut water and eating the tender meat give many benefits to the body for it dangerous tasks in processing it. To consume their flesh meat and the juice, trimmed coconuts must be opened either manually or mechanically (Jarimopas, Ruttanadat, & Terdwongwarakul, 2009). Young coconuts sold in the restaurants, stalls or even in the fresh markets are usually trimmed in a sort of conical shape (Mohanraj, Rahgul Krishna, Kannan, Rajkumar, & Elango, 2014). The process of trimming requires skills which only can be obtained it is done daily and it would be possible only for those who runs the young coconuts business and also for the agricultural biomass industries (Salleh, Mohd Yusoh, & Ruznan, 2015; Sim, Mohd Irwan Lu, Lee, Mohamed, 2015). Thus, for the commoners, it is still a dangerous task (Ismail et al., 2015). Traditionally, in current practice the process of removing the top and bottom husk is by chopping them off. The process of removing the husk really needs a cautious move and focused mind in order to maneuver the sharp and heavy object to cut the husk (Abraham, Girish, Vitala, & Praveen, 2014). Furthermore, the oval shape of the coconut produces instability during the cutting process, thus it adds up the percentage of accidental injuries.

Even though there are already devices which almost have similar functions to the device which is going to be developed but there is still room for improvement (Vinod, Ketan, & Chandrashekhar, 2014). Some of the available products developed are not meant for the small scale entrepreneur or home users (Prashant, Gopinath, & Vignesh, 2014). The existing product in the market is big (for mass production), custom made, not portable, complicated to be operate, expensive and dependent to other sources such as hydraulic, pneumatic and power supply (Sabale & Kolhe, 2015; Sangameshwara & Ravaikiran, 2015; Satip & Kiattisak, 2008). Thus, it is an advantage to design the young coconut processing apparatus that is independent from other sources, portable with optimum size, user friendly, and not too costly compared to the existing product.

It is observed that, the possibility of a non professional chopper tends to get injured during processing the young coconut is extremely high. This dangerous task could invite accidental injuries if it is performed by the non-experts in the field (Vasconcelos & Junior, 2015). Thus, the development of an apparatus could help people to avoid the accidental injuries during processing of the young coconut fruits. Therefore, this paper focuses on designing and developing a portable multi-tasking device which can eliminate and reduce the hazardous task and fasten the time taken on processing the young coconut fruits when compared to the conventional processing steps.

## **MATERIALS AND METHODS**

### **Design Requirement**

The design requirement is derived from the needs of the client such as mechanisms, performance of the client such as the mechanisms, performance parameters, reliability, and safety. These elements will derive and control the design and constraints throughout the process. This is to determine the critical process which can cause the accidental injuries and concurrently will provide ideas during designing stage at product level.

### **Conceptual Design**

The design concept of total physical shape of the young coconut processing apparatus was performed. The design concepts addressed the problem highlighted. In this process, the entire elements such as design requirements, the customer needs and constraints were considered in order to satisfy the needs.

### **Preliminary Design**

In this stage, the overall system configuration is defined, and drawing definition will be developed to provide early project configuration and to assist coordination during the detail design phase.

### **Data Collection**

Before developing the detail design phase, a few crucial data were required to obtain which are, (i) dimension of the young coconut fruits, and (i) the force required in order to punch a hole on the top of the endocarp and to cut the young coconut into halve. The defined dimensions such as, (i) the height of the young coconut fruit before the removal of the top and bottom husk, H1, (ii) the height of the young coconut fruit after the removal of the top and the bottom husk, H2, and (iii) the diameter of the young coconut fruit, D. The data collection was to provide dimensions and measurement that would allow further construction of the detail design on the product component level. The data of 30 samples

of different types, sizes and origin of the young coconut fruits were collected. For the study purposes, the selection of the coconut fruits relied totally on the experienced of the young coconut water sellers. The issue of maturity of the young coconut fruit was not really important as long as it falls under the category of young coconut fruit.

### **Detail Design**

A detail design of each parts of the device at main and sub level were produced. All the manufacturing drawing such as details drawing, 3D drawings, general assembly drawing, general sectional assembly drawing and exploded drawing were constructed. For the details drawing on components and assembly level, 3<sup>rd</sup> angle orthographic projection were used. This was performed using the parametric modeling software, CATIA V5R19.

### **Product Modeling**

The 3D modeling software CATIA V5R19 was used to model the young coconut processing apparatus. All the freehand sketches of the conceptual and the preliminary design were detailed using this software. The dimensions and form of each component was assessed and defined based on the engineering design analysis and also with Heuristic design technique. The product and its sub element would be simulated concurrently during modeling phase. This process was to determine the feasibility of assemblage and the tolerance needed.

## **RESULTS AND DISCUSSION**

### **Conceptual Design**

A few design concepts were performed. The design concepts were in line with the objectives points of the apparatus which include, (i) the hazardous task of chopping the top and the bottom husk, (ii) cutting the young coconut into halves after the drainage of its water, (iii) creating an access at the top of the endocarp for the young coconut water draining purpose, (iv) the apparatus has still to be operated in manual mode but without the chopping process, and (v) the husk removal process has to assemble like the sawing or slicing process.

Figure 1 shows the preliminary design 5 into sub-units. The main function of the device is, (i) to remove the top husk, (ii) to remove the bottom husk, (iii) to create a hole through the top endocarp, and (iv) to cut the young coconut into two parts. As indicated in Figure 2, the sub-unit 1 shows the Positioner which the aim of this sub-unit is to position the young coconut vertically and horizontally and to provide stability to the young coconut – additional contact point. It is also designed to allow rotation to the young coconut. Sub-unit 2 shows the Base which the objective of this part is to provide rigidity and stability of the device. Meanwhile, sub-unit 3 is the Slicer. It is designed for slicing the husk (top and bottom) and to cut the young coconut into two parts. The sub-unit 4 is the Slicer Pivoting Mechanism

which is designed to provide rotation and sliding angle to the knife and the sub-unit 5 is the Puncher. The role of the Puncher is to create access through endocarp of the coconut.

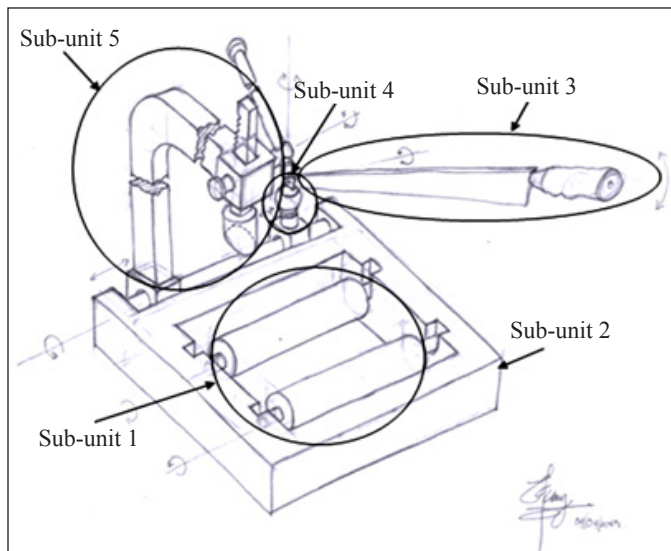

Figure 1. Preliminary design for five (5) sub-units

### Data Collection

The data provides the maximum and minimum dimension of H1, H2, and D from the 30 samples of the young coconut fruits. Figure 2 shows the defined dimensions of the young coconut fruit. By rearranging the data, it defines the working area (WA) of the apparatus to be developed as viewed in 3-dimensional views. The WA was presented in Figure 3. The WA will be the constraints of effective working area to the development of the total size of the apparatus. Figure 4 shows the young coconut processing apparatus working area terms definition.

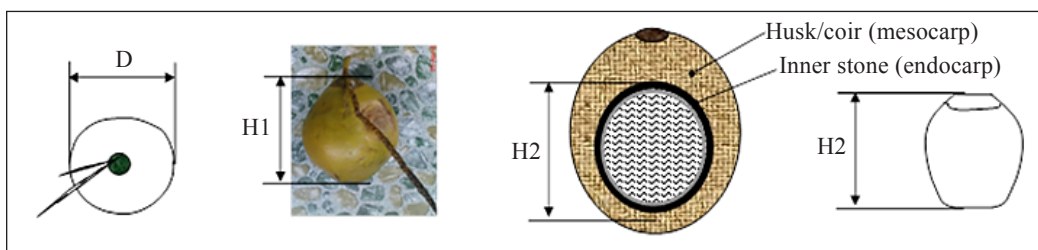

Figure 2. Young coconut fruit defined dimensions

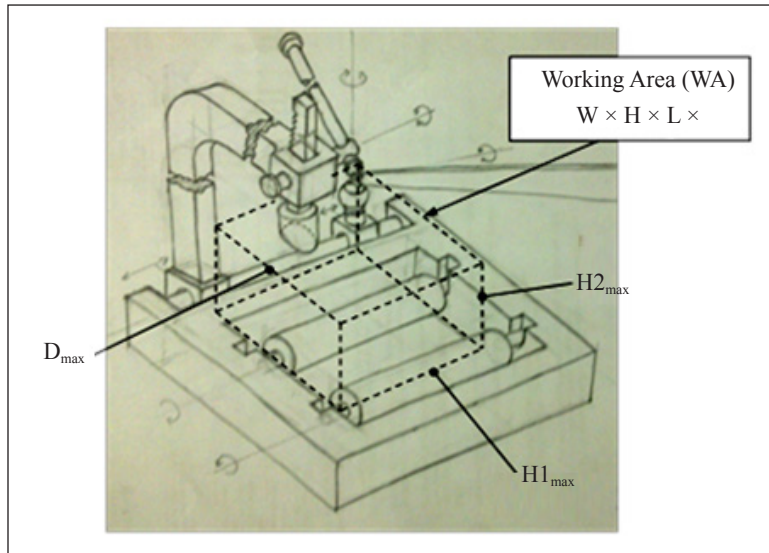

Figure 3. Young coconut processing apparatus's working area

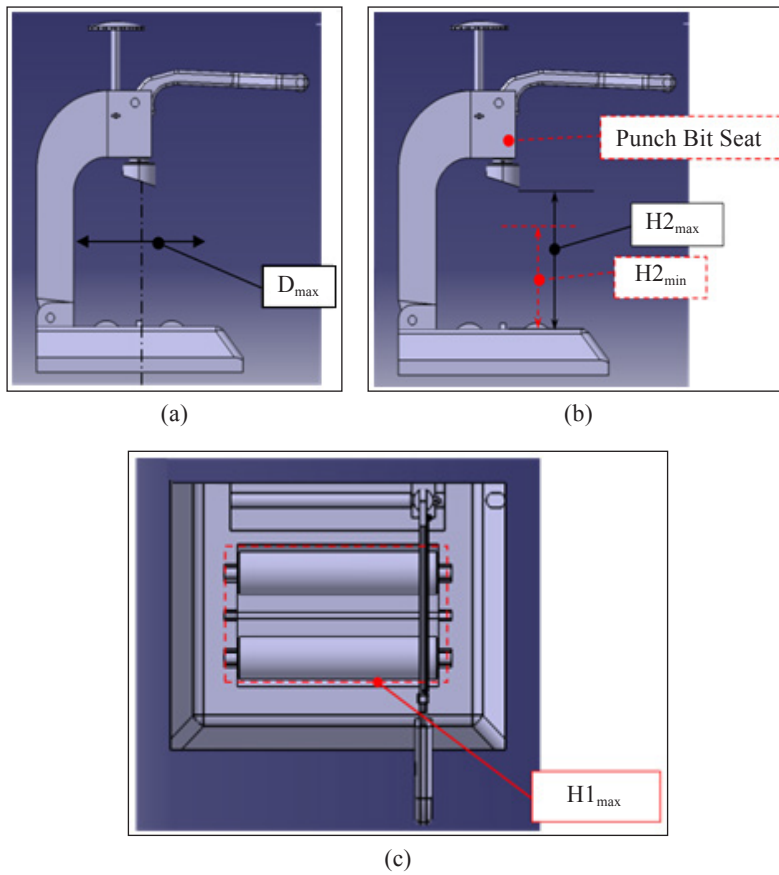

Figure 4. Young coconut apparatus working area terms definition

In Figure 4, the width ( $W$ ) can be obtained from the dimension of  $D_{\max}$ ; the height ( $H$ ) can be obtained from the dimension of  $H2_{\max}$ . The length of the WA is obtained from the dimension of  $H1_{\max}$ . The purpose of  $H2_{\min}$  is to provide the minimum height of the young coconut fruit. This data enabled to design the punch bit head to be lowered to the minimum height ( $H2$ ) of the young coconut. The difference between  $H2_{\max}$  and  $H2_{\min}$  acts as the tolerance range for the punch bit seat to keep functioning.

### Punch Bit

The Punch bit part is designed with the slant angle of  $18^\circ$  as viewed in Figure 5. The purpose of the designed punch bit is to reduce the surface area during the penetration to the endocarp of the young coconut which would reduce the pressure on the target surface. In this part, the target surface is located between the tip of the punch bit and the top endocarp of the young coconut. The reduced value of the pressure acts directly on the target surface will reduce the force to be applied during punching process. As indicated in Figure 5, the selected angle of  $18^\circ$  provides a small value of the penetration length. The smaller value provides faster complete penetration at the top endocarp of the young coconut fruit.

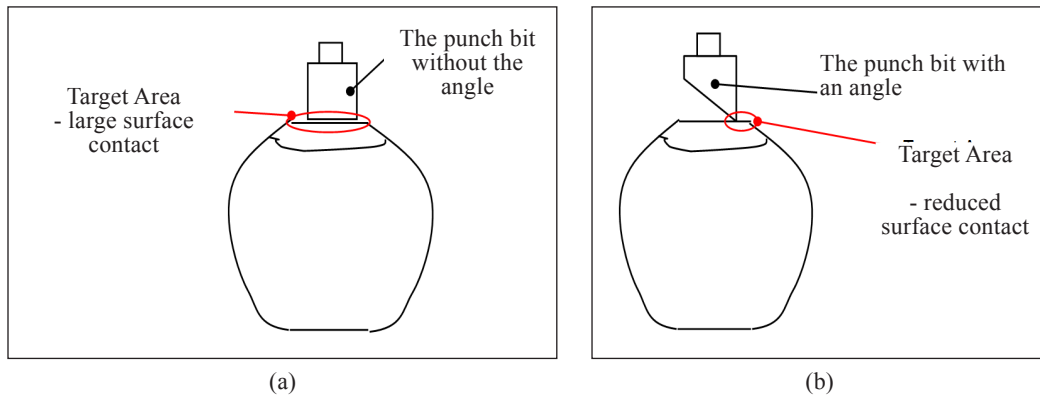

Figure 5. The effective area of a punch bit design

### Punch Bit Seat

The punch bit seat is designed in moveable vertical direction. It can be adjusted to accommodate tolerance zone between  $H2_{\max}$  and  $H2_{\min}$ . As for the punch bit seat not to be disoriented while being lowered, a guide column is embedded in the component. Figure 6 shows the different position of the punch bit seat.

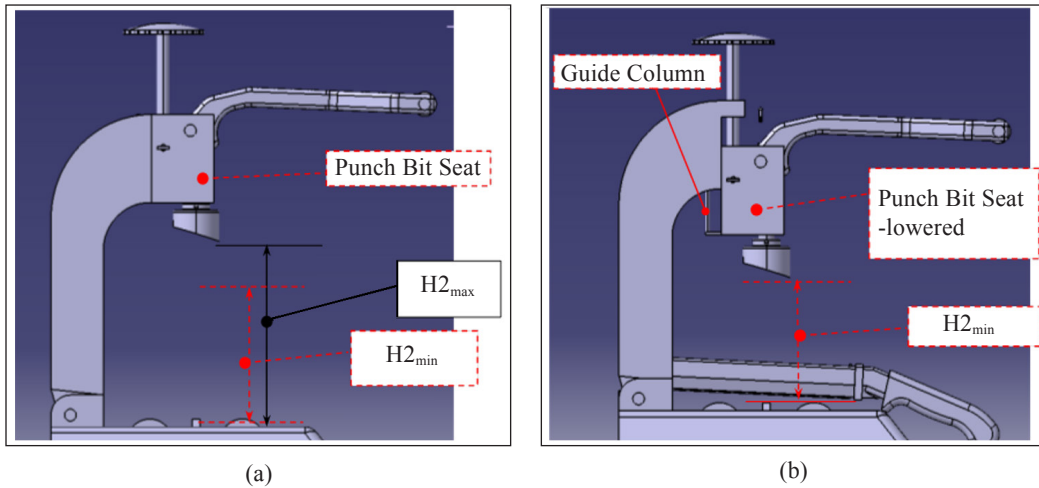

Figure 6. The different position of the punch bit seat

### Punch Lever

The designed punch lever in Figure 7, can be used for left and right handed person. When one pressing the punch lever downwards, the roller will rotate with respect to the axis center. This would act as a friction reducer between the palm skin and the roller.

### Blade Shutter

As for the safety purpose when handling the sharp blade during cutting and slicing process or when the apparatus is not being used, the sharp blade has to be remained in safety mode. This is to avoid any accidental injuries that can be caused by the sharp blade. Thus, the blade shutter is designed to cover the blade sharpness. The blade shutter is forced upward during the slicing and cutting process while it returns to its initial position when pulled by the gravity which acts on its own mass as shown in Figure 8.

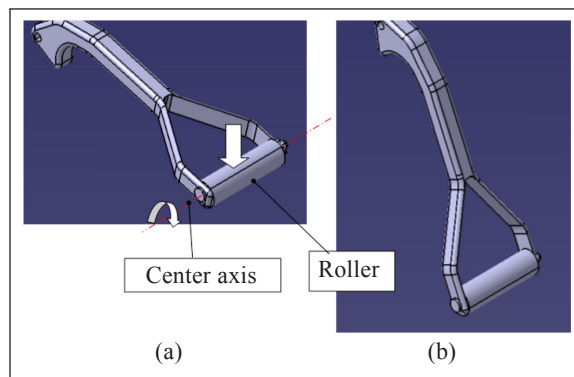

Figure 7. Puncher lever



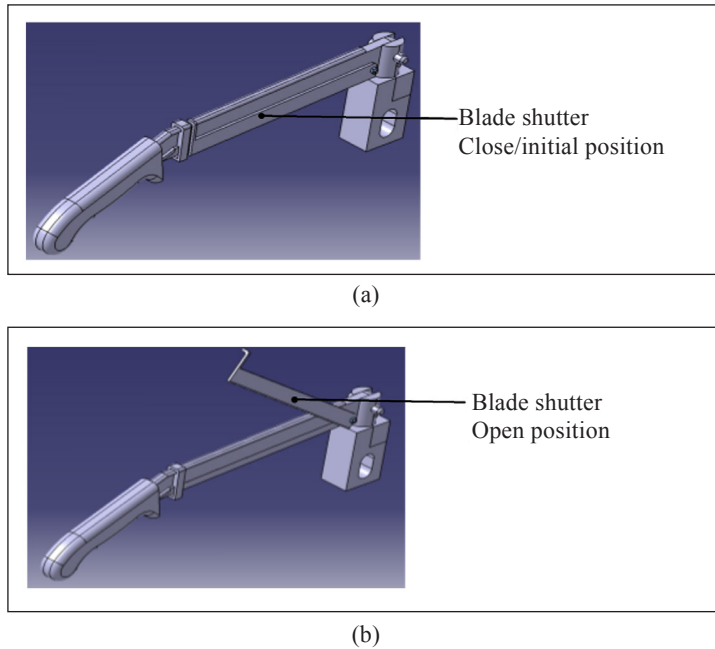

Figure 8. Blade safety mechanism

The angle of the blade holder was designed to comfort during handling the blade. The selection of the angle value is based on the observation of the normal position and condition during holding and grasping an object in standing position. As a result, an angle of  $20^\circ$  was selected to mimic the position of hand grasping or holding and object pointing outward as shown in Figure 9.

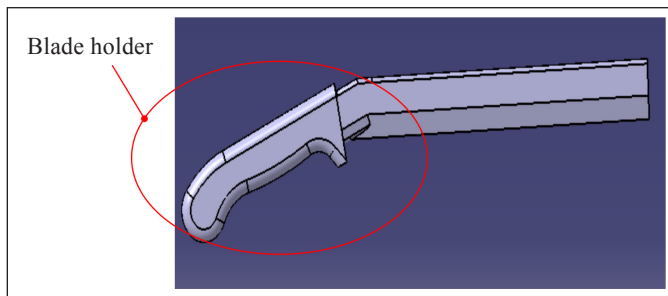

Figure 9. Blade holder design

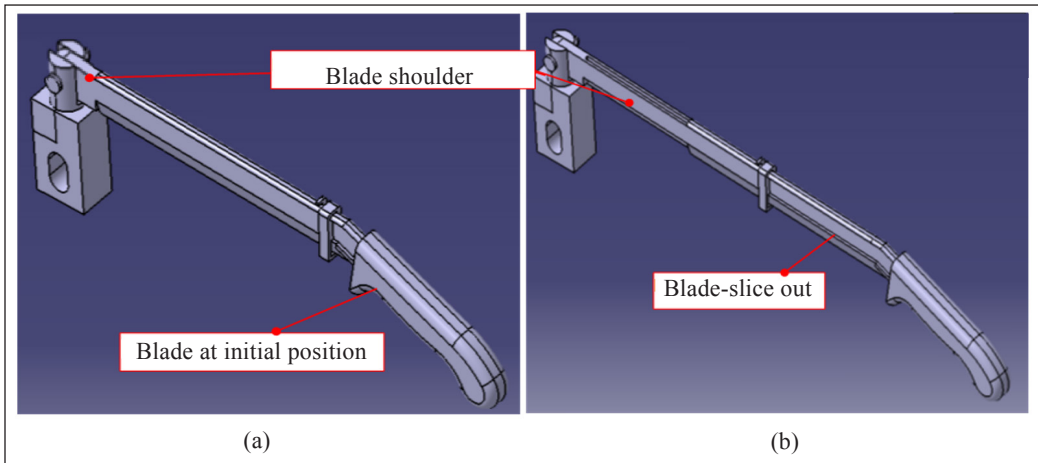

Figure 10. Slicing movement of the blade with respect to its holder

### Blade Slicing Feature

In addressing the main problem (to eliminate the chopping process) of the development of the apparatus, the slicing method is proposed to replace the chopping technique. The slicing feature will ease the process of removing the husk by facilitating the blade to make the first cut on the husk. The process of removing the husk resembles the wood sawing process as shown in Figure 10.

Knife angle is the angle of the blade which is referred to the X-axis viewed from the XY plane shown in Figure 11. By putting the blade in an angled position will reduce the surface area contact between the husk and the respective blade area as justified by Pressure's law.

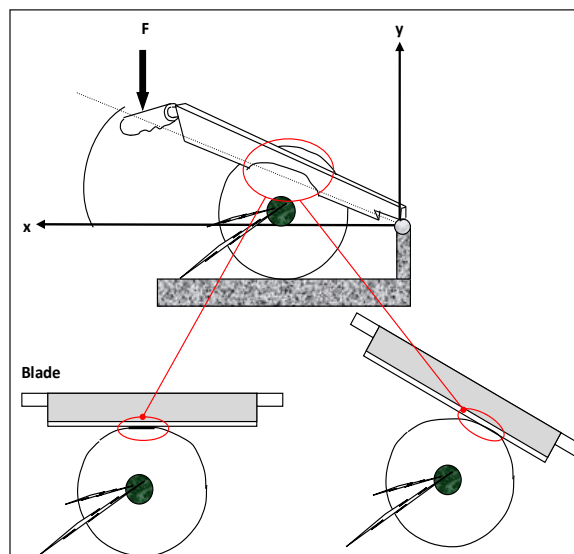

Figure 11. The blade angle during cutting process

### Product Modeling

The young coconut processing apparatus was modeled using CATIA V5R19 as shown in Figure 12. The software is chosen because the application provided makes it easy to manipulate the model and thus, convenient to alter the 3D buildup. In product modeling, the solid design is used. All components and subassembly of the product are assembled as to resemble the final product.

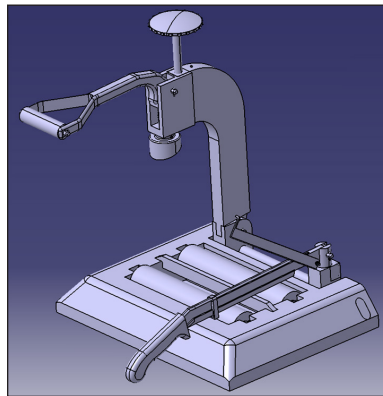

Figure 12. Young coconut processing apparatus modeling using CATIA V5R19

### Punch Bit Head Analysis

The pressing force that acts on the roller of the punch lever is transmitted to the punch bit head. An amount of 1471N is required to penetrate the top endocarp of the young coconut fruit. Thus, the minimum pressing force to be applied to punch lever is equivalent to the penetrating force as shown in Figure 13.

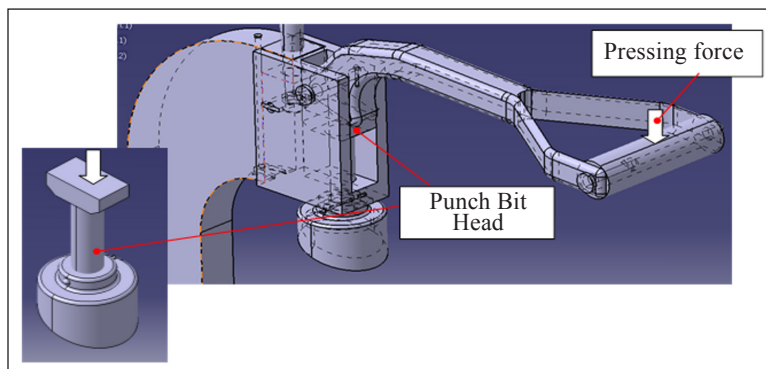

Figure 13. Punch bit head

The stress applied on this designed component were analyzed based on these two justifications; (i) if the applied stress,  $\alpha_{apl}$ , is greater than the material compressive yield strength,  $\alpha_y$ , and (ii) if the buckling force is smaller than the applied stress,  $\alpha_{apl}$ . Thus, it can be said that, if one of the justification is true, then the component with the defined diameter is considered fail.

Consider that the selected material is cast iron ASTM A-197 with modulus elasticity of 172 GPa and its compressive ultimate strength,  $\alpha_{ult}$ , is 572 MPa.

$$\sigma_{apl} = \frac{F}{A} = \frac{1471N}{3.1416 \times 10^{-4}m^2} = 4.6823MPa$$

Inculcating the safety factor of 1.5 into the  $\alpha_{apl}$ . This is to defined that the system will not fail if under excessive force. Thus the new applied stress,

$$\sigma_{new} = \text{safety factor} \times \sigma_{apl} = 7.0235 MPa$$

$$F_{new} = \text{safety factor} \times \sigma_{apl} = 2206.5 N$$

It shows that,  $\alpha_{apl} < \alpha_{ult}$ , thus the punch bit head with diameter of 20 mm does not fail under the compressive stress of 7.0235 MPa.

Meanwhile, according to the Euler Buckling Column,

$$F_{buck} = \frac{\pi^2 EI}{(KL)^2} = 12.62 MPa$$

Where  $E$  is the modulus of elasticity,  $I$  is the area moment of inertia,  $K$  is the column effective length factor, and  $L$  is length.

With the  $F_{buck} = 12.62 MPa$  and  $F_{new} = 2206.5 N$ , it shows that the  $F_{buck} > F_{new}$ , thus the round shaft with diameter of 20 mm won't buckle if a force of 2206.5 N is exerted on the shaft.

Based on the weight and the design proposed, the device is categorized as a portable and easy to handle. Although most of the components are suggested to be made of iron and steel, the total weight of the apparatus is 29.171 kg, where it became the lightest young coconut processing apparatus available in the market. This is finalized using the utilization of 3D modeling software CATIA V5R19 which instantly shows the effect on the weight by changing the material used.

## CONCLUSION

Although the device is still not being materialized, but based on engineering analysis and the 3D product modeling, it shows that the potentials and the advantages of the device. In general, by executing a proper study on the development of any product, the design of the device can be optimize prior to the development process. It also can reduce tremendously the possibility of error to occur. The device developed eliminates the hazardous task by eliminating the chopping process and replacing it with the slicing process. The blade of the device is designed to allow the slicing movement to be maneuvered during the husk removal process. Therefore, the tendency to get caught in accidental injury during the chopping process can be significantly reduced. Meanwhile, the puncher has replaced the usage of the copper in creating an opening at the top of the endocarp. Thus, the opening can be made easily whereby it is not possible conventionally.

## ACKNOWLEDGMENTS

The author would like to thank to the Ministry of Higher Education Malaysia and Universiti Putra Malaysia (UPM) for supporting this work. The author, Muhamad Hellmy Hussin would like to thank to Universiti Kuala Lumpur Malaysia France Institute (Unikl MFI) and Majlis Amanah Rakyat (MARA) for granting a fellowship for his Masters study.

## REFERENCES

- Abraham, A., Girish, M., Vitala, H. R., & Praveen, M. P. (2014). Design of harvesting mechanism for advanced remote-controlled coconut harvesting robot (A.R.C.H-1). *Indian Journal of Science and Technology* 7, 1465-1470.
- Adzimah, S. K., & Turkson, S. O. (2015). Conceptual design of coconut dehusking machine. *Innovative Systems Design and Engineering* 6, 1-10.
- Ismail, N. F., Sulong, A. B., Muhamad, N., Tholibon, D., Md Radzi, M. K. F., & Wan Ibrahim, W. A. S. (2015). Review of the compression moulding of natural fiber-reinforced thermoset composites: Material processing and characterisations. *Pertanika Journal Tropical Agricultural Science*, 38(4), 533-547.
- Jarimopas, B., Ruttanadat, N., & Terdwongwarakul, A. (2009). An automatic trimming machine for young coconut fruit. *Biosystems Engineering* 103, 167-175.
- Ketan, K. T., Vinod, P. S., & Sakhale, C. N. (2014). Design and performances of coconut de-shelling machine. *International Journal of Engineering Research and Applications*, 4, 39-44.
- Lihua, W. (2015). Design of coconut feeding machine based on motion controller. *Journal of Applied Science and Engineering Innovation* 2, 160-162.
- Mani, A., & Jothilingam, A. (2014). Design and fabrication of coconut harvesting robot: COCOTOT. *International Journal of Innovation Research in Science, Engineering and Technology* 3, 1351-1354.

- Mohanraj, A. P., Rahgul Krishna, S., Kannan, S. S., Rajkumar, M., & Elango, A. (2014). Design and analysis of a coconut harvesting maneuver. *International Journal of Scientific & Engineering Research* 5, 508-512.
- Prashant, Y., Gopinath, C., & Vignesh, R. (2014). Design and development of coconut fiber extraction machine. *SasTech Journal* 13, 64-72.
- Sabale, R., & Kolhe, K. P. (2015). Review of coconut fiber extraction machines. *International Journal of Science, Engineering and Technology Research* 4, 1269-1273.
- Salleh, J., Mohd Yusoh, M. K., & Ruznan, W. S. (2015). Tensile strength of some natural-fibre composites. *Pertanika Journal Tropical Agricultural Science*, 38(4), 575-582.
- Sangameshwara, G. S., & Ravaikiran, B. S. (2015). Design and fabrication of portable virgin coconut oil extracting machine. *International Journal of Engineering Research and General Science*, 3, 271-275.
- Satip, R., & Kiattisak, R. (2008). Design and development of semi-automatic cutting machine for young coconuts. *Maejo International Journal of Science and Technology*, 1-6.
- Sim, F. S., Mohd Irwan Lu, N. A. L., Lee, Z. E. T., & Mohamed, M. (2015). Removal of dissolved organic carbon from peat swamp runoff using assorted tropical agriculture biomass. *Pertanika Journal Science & Technology*, 23(1), 51-59.
- Syafriani, R., Sukandar, E. Y., T., Apriantono., & Sigit, J. I. (2014). The effect of coconut water (*Cocos nucifera* L.) and an isotonic drink on the change of heart rate frequency in the rats induced hypertension. *Procedia Chemistry*, 13, 177-180.
- Vasconcelos, B., & Junior, B. B. (2015). The causes of work place accidents and their relation to construction equipment design. *Procedia Manufacturing*, 3, 4392-4399.
- Venkataramanan, S., Abhinav Ram, B., & Rahul, R. (2014). Design and development of automated coconut dehusking and crown removal machine. *Internationa; Journal of Sciences: Basic and Applied Research*, 13, 183-219.
- Vidhan Sigh, T., & Udhayakumar, R. (2013). Development of a coconut de-shelling machine. *Tropical Agricultural Research*, 18, 1-8.
- Vinod, P. S., Ketan, K. P., & Chandrashekhar, N. S. (2014). Design and development of coconut de-husking machine. *International Journal of Engineering Research and Technology* 3, 1-6.
- Yahya, S., & Zainal, M. (2014). Design and performance of young coconut shaping machine. *Journal of Tropical Agricultural and Field Sciences* 42, 19-28.
- Yuniwanti, E. Y. W., Asmara, W., Artama, W. T., & Tabbu, C. R. (2015). Virgin coconut oil supplementation increased the survival of Avian Influenza Virus (H5N1) infected chicken. *Asian Journal of Poultry Science*, 9(2), 106-111.